

Assembly instructions for the SimPlexity V8 cockpit

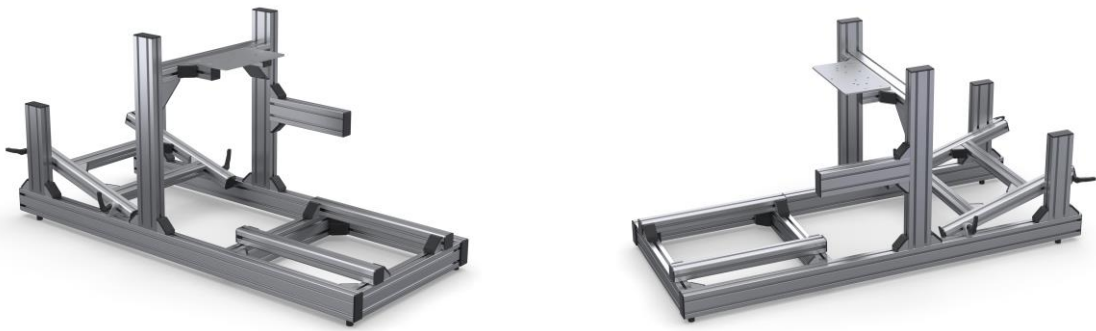

In order to make everything easy to identify we have color coded the aluminum profiles.

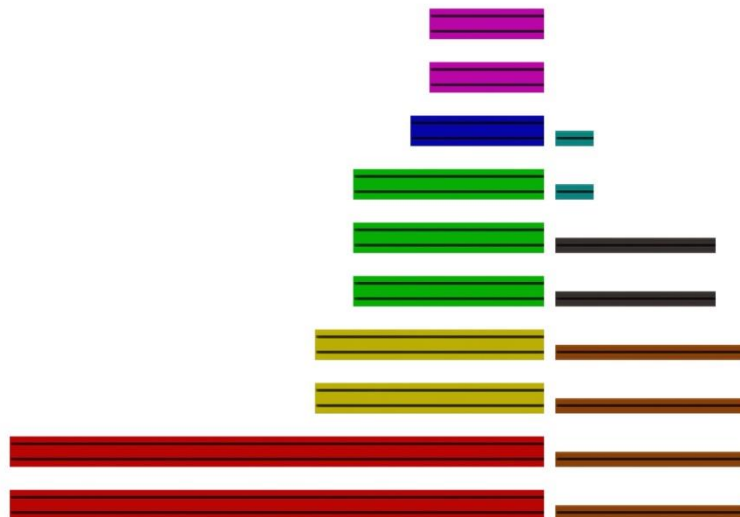

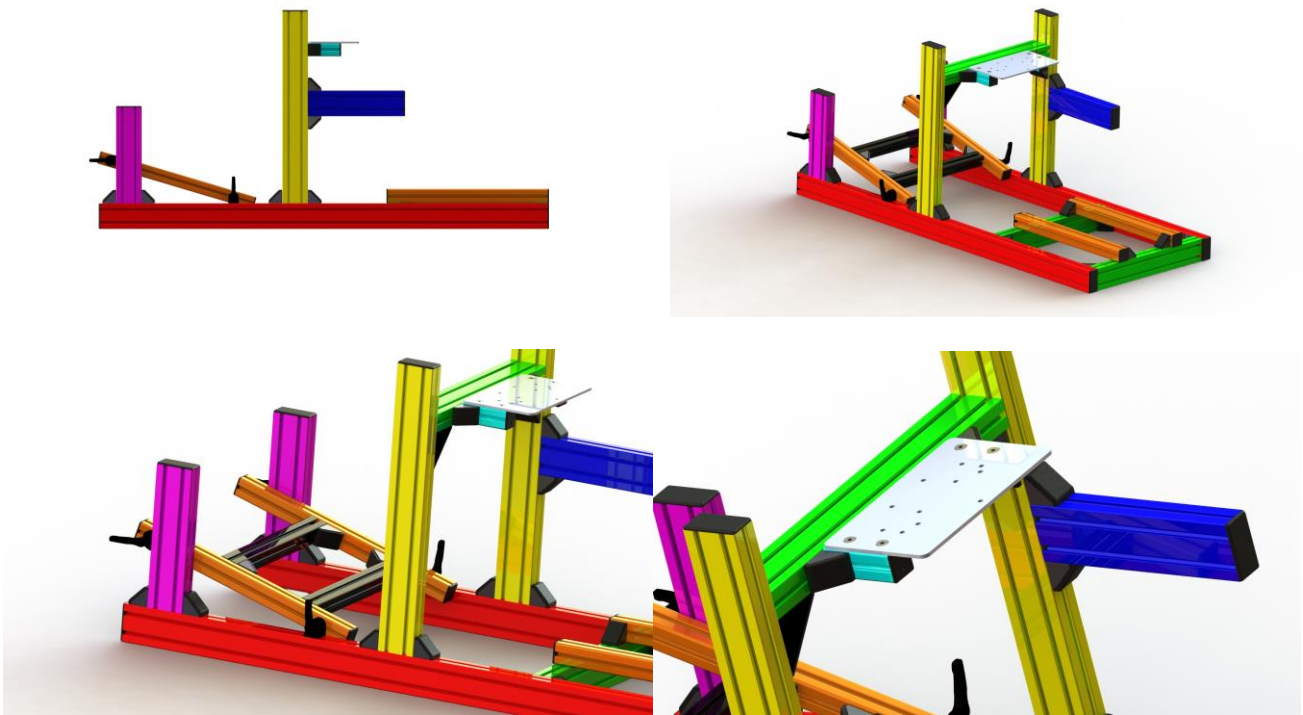

The following picture demonstrates the how the brackets are attached to the profiles.

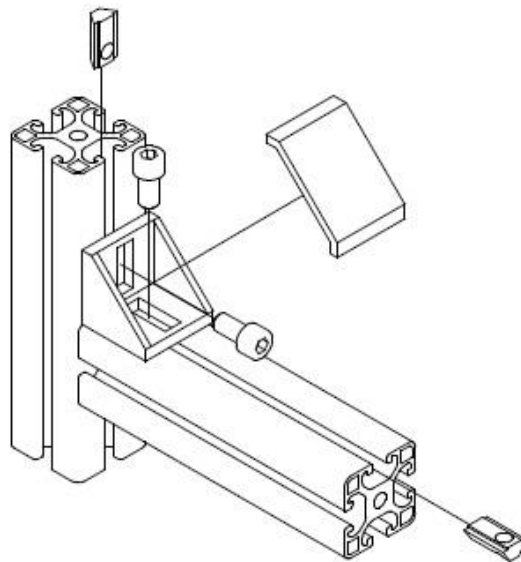

In some cases you will have to break off the guiding feet of the brackets. That can be easily done by prying them with a screwdriver.

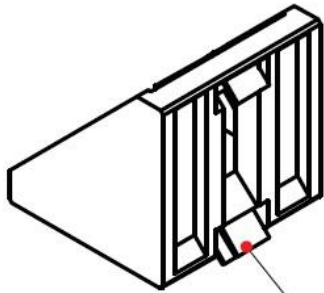

Break-off the lip
with a screwdriver

Tips:

- It is a good idea to start by building the base of the cockpit. For this you will need two red 40x80 and two green 40x80 profiles. The two green profiles should not be farther than 42cm from each other. The distance can easily be approximated by using a orange 40x40 profile as they are 50cm long. The feet can be attached now as well. Make sure the ones that will be under the seat are about 10 cm away from the end of the cockpit.
- After the base is assembled, it is a good idea to assemble the pedal frame and adjust it to fit the pedals. For this you will need two black 40x40 profiles and two orange 40x40 profiles.
- The remaining steps can be done in any order.
- When attaching the wheel plate, first attach the two light blue 40x40 profiles (the smallest ones) to the wheel plate itself using the countersunk screws. Afterwards attach a bracket on the outside of the profiles and then the entire

assembly to the green horizontal 40x80 profile. You can now remove the wheel plate and attach the inner brackets.

- As a general recommendation to make the adjustment of the cockpit easier, for a person with a height of approximately 180cm, the yellow upright 40x80 profiles should be 70cm from the seat end of the cockpit. The green horizontal 40x80 profile on which the wheel plate is attached should be approximately 10cm from the top of the yellow 40x80 profile.
- Make sure everything is tight and hit the track! 😊